

DRV8825 Stepper Motor Driver Module



Produktkode: 389aa

Tilgjengelighet: Opp til 1 mnd leveringstid

Pris: kr. 25,00

Short Description

DRV8825 Stepper Motor Drive Carrier+Silent Step Stick Protector for 3D Printer

Beskrivelse

Stepper Motor Driver Module DRV8825 for 3D Printer
RepRap 4 RAMPS1.4 StepStick

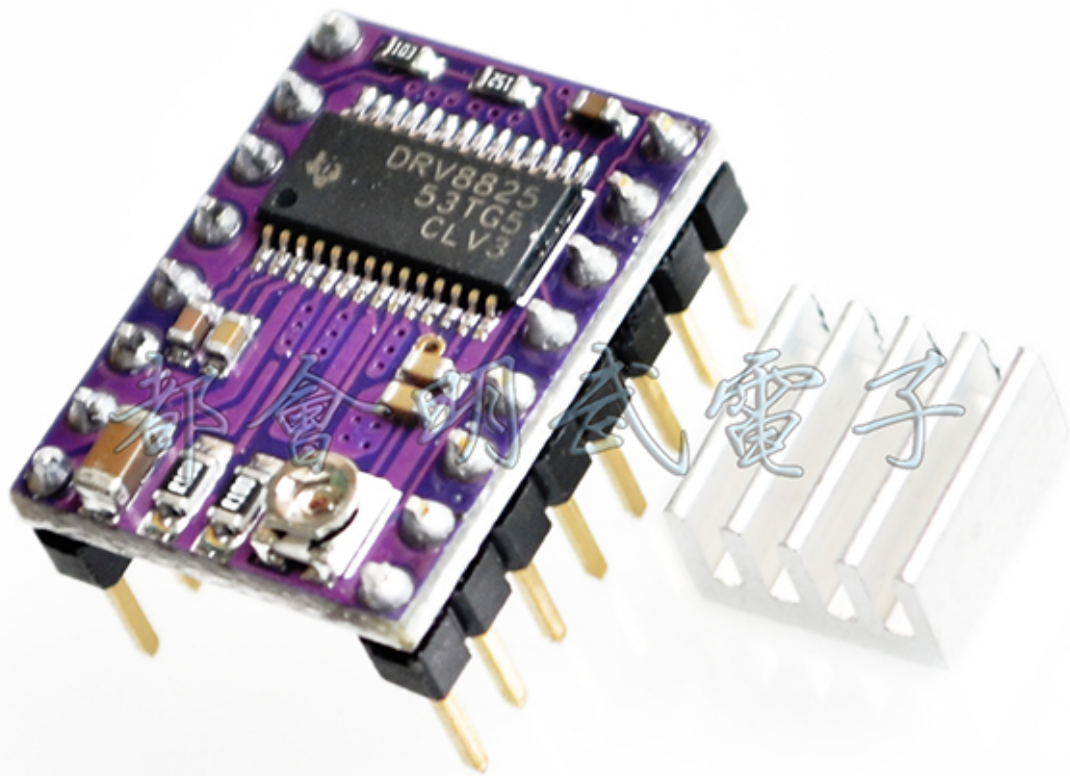

Description:

The DRV8825 stepper motor driver carrier is a breakout board for TI's DRV8825 microstepping bipolar stepper motor driver. The module has a pinout and interface that are nearly identical to those of our A4988 stepper motor driver board, so it can be used as a higher-performance drop-in replacement for those boards in many applications. The DRV8825 features adjustable current limiting, overcurrent and overtemperature protection, and six microstep resolutions (down to 1/32-step). It operates from 8.2 – 45 V and

can deliver up to approximately 1.5 A per phase without a heat sink or forced air flow (rated for up to 2.2 A per coil with sufficient additional cooling).

Features

Simple step and direction control interface

Six different step resolutions: full-step, half-step, 1/4-step, 1/8-step, 1/16-step, and 1/32-step

Adjustable current control lets you set the maximum current output with a potentiometer, which lets you use voltages above your stepper motor's rated voltage to achieve higher step rates

45 V maximum supply voltage

Built-in regulator (no external logic voltage supply needed)

Can interface directly with 3.3 V and 5 V systems

Over-temperature thermal shutdown, over-current shutdown, and under-voltage lockout

Short-to-ground and shorted-load protection

4-layer, 2 oz copper PCB for improved heat dissipation

Exposed solderable ground pad below the driver IC on the bottom of the PCB

Module size, pinout, and interface match those of our A4988 stepper motor driver carriers in most respects (see the bottom of this page for more

information)

Package Included:

1 x Stepper Motor Driver Module DRV8825 for 3D Printer RepRap 4
RAMPS1.4 StepStick

Pinout

DRV8825 Stepper Motor Driver

Power Plug 12V

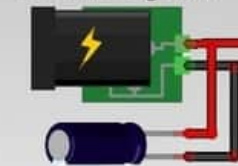

Power Plug 5V

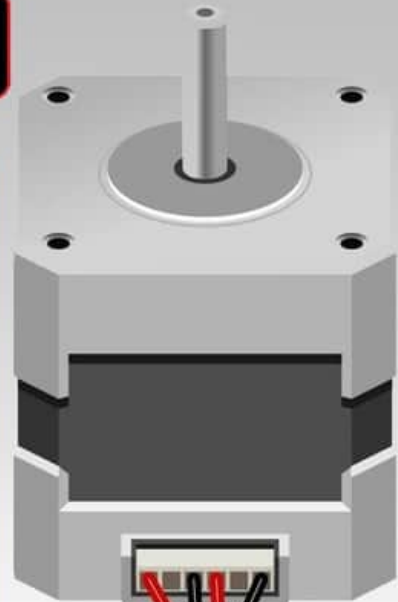
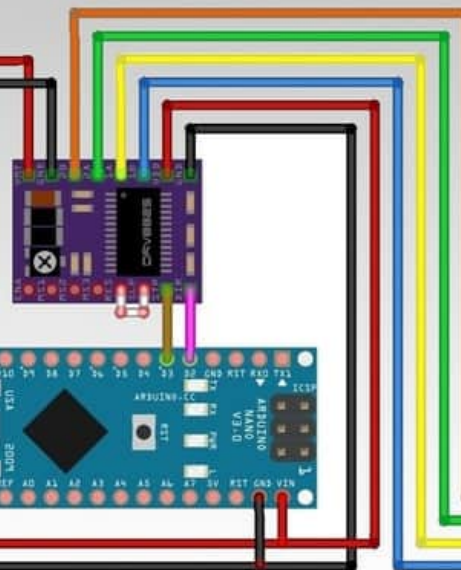
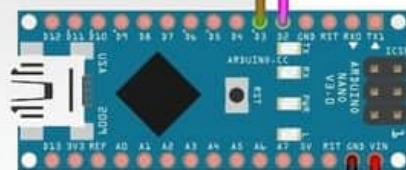
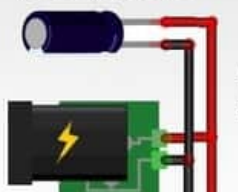

logic power supply
(2.5–5.25 V)

motor power supply
(8.2–45V)

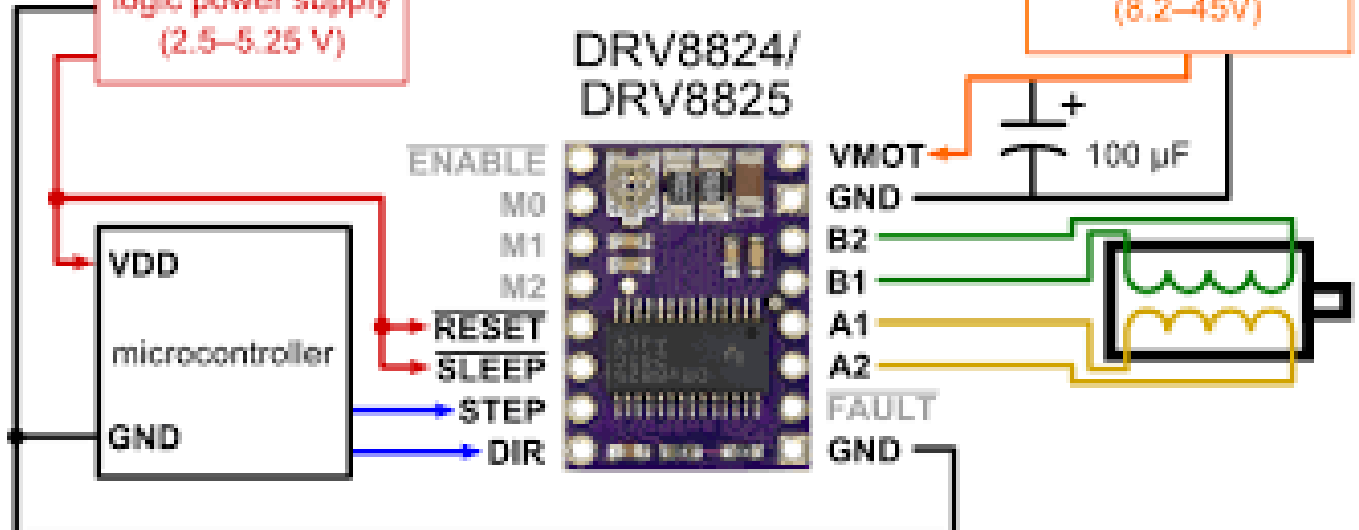

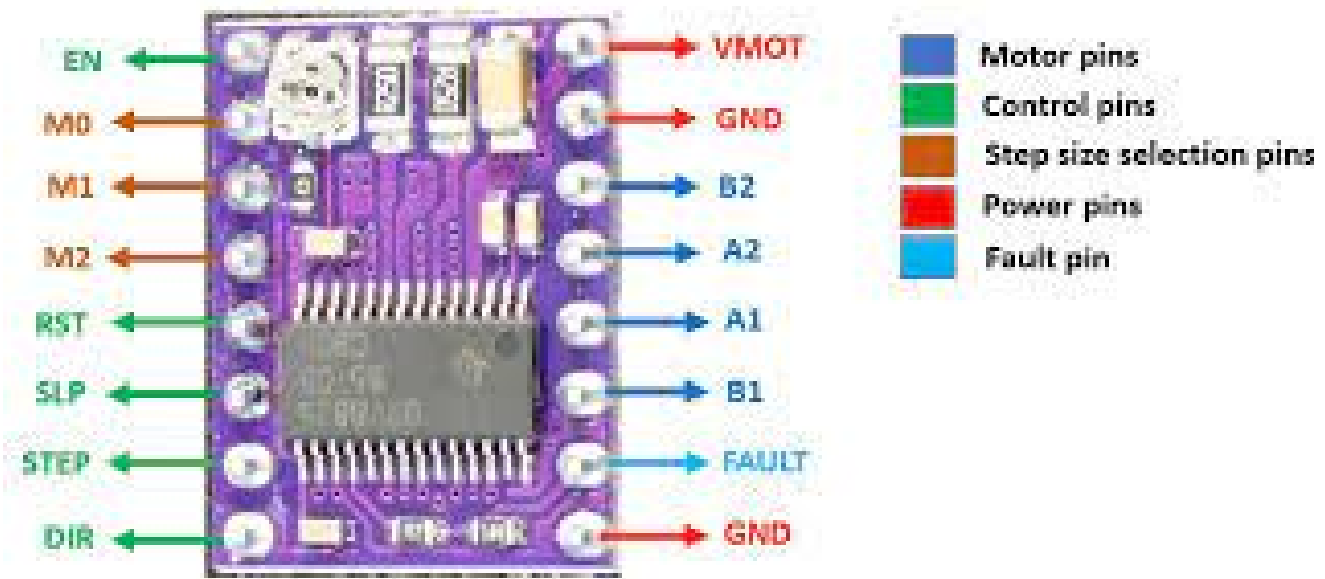
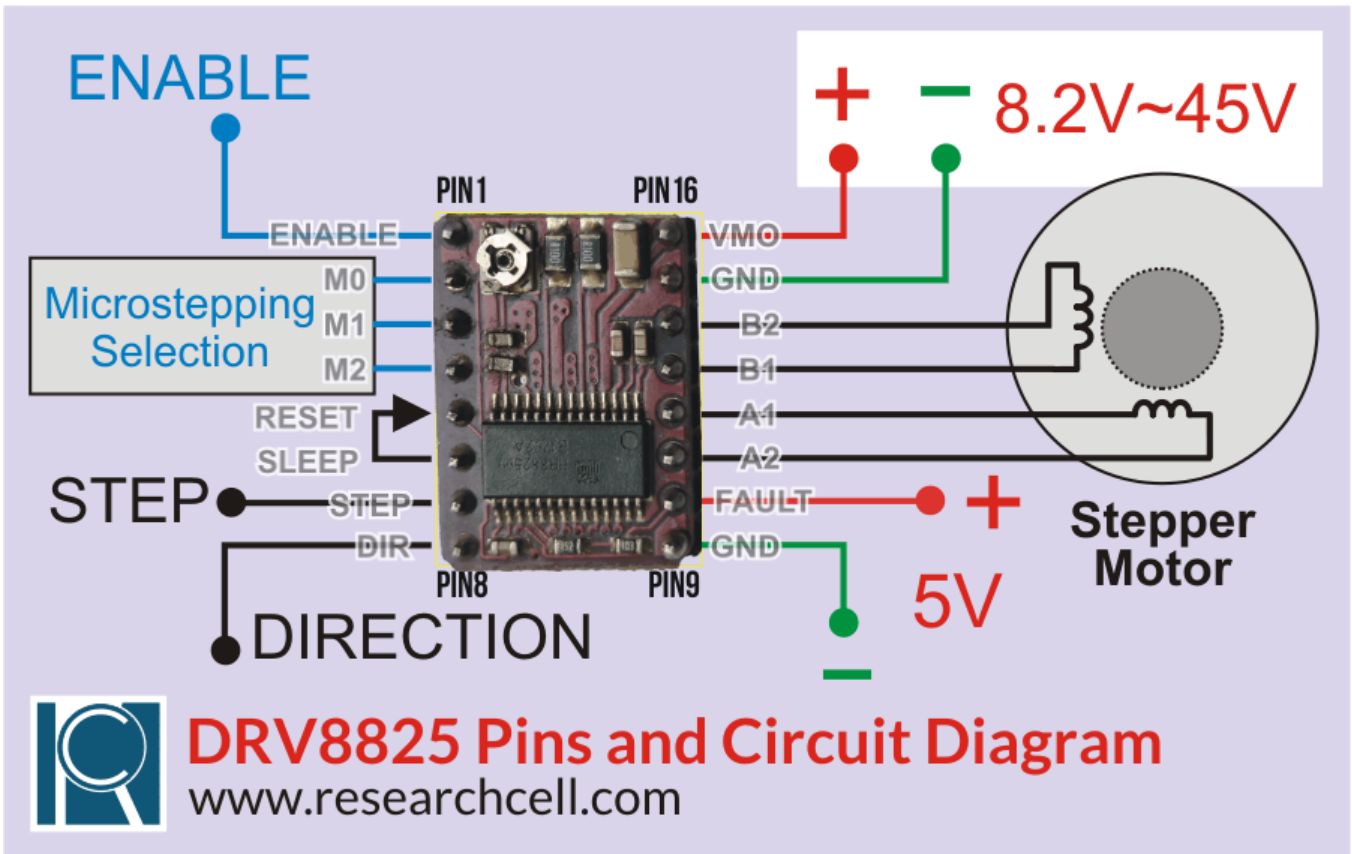

Product Gallery

